

KIB ENTERPRISES

53402 C.R. 13 • Elkhart, IN 46514
Phone: (574) 262-0518 • Fax: (574) 262-5172

Monitor Panel

Monitor Features

K-PANEL SYSTEMS

FUNCTIONS

Allows monitoring of fresh water, gray water, black water, and battery levels. All functions are controlled from one test switch for easy operation. Optional functions allow monitoring of LP gas, and a fourth water tank. All panels also have a lighted pump switch to control the power to the water pump.

DECOR

We have two types to offer. The first being a wall mount type and the other designed to install into most popular range hood vents.

The entire wall mount type is mounted in a black ABS bezel with easy to clean matte finish lexan labels for continued good appearance. The overall size is only 3 9/16" H X 4 7/8" W and it is only 3/4" deep when mounted on the wall.

The range hood model is constructed out of 18ga. steel with the same type of matte finished label as the wall mount. This type also has switches in it for controlling the fan and light in the range hood vent.

Both models can be built with your custom labels using your company logo, custom colors, etc. upon approved agreements.

CIRCUITRY

The electronics is using integrated circuit technology with complete voltage regulation, for the most reliable circuit design in the industry. This assures proper level displays with a wide range of input voltage from around 9VDC all the way up to 35VDC. Eliminating erroneous level display from weak batteries and power surges caused by some converters and generators. All displays are multi-color lighted by solid-state L.E.D.'s to eliminate the burnout problems from incandescent light bulbs.

POWER REQUIREMENTS

The systems only draws power when a switch is on, causing no battery to drain while not in use. The monitor panel display consumes 175ma. maximum with all options and only during the time the test switch is pushed on. The only other consumption is the draw of your pump, light, or fan if they are in use.

INSTALLATION

The monitor panel attaches to the all with four #4 flat head screws and the faceplate with the circuitry snaps into the bezel over these screws for a very clean appearance. The range hood model snaps into the opening in the front of the range hood vent, again for a very clean appearance.

The tanks have a very small pigtail attached to your probes requiring only one wire to return to the panel from each tank and one combined ground wire for all tanks. These wires can be as low as 22 gauge, eliminating the need for a bulky and expensive multi-wire harness to go to each tank.

SERVICEABILITY

This system is designed for trouble free operation, however, it is also designed for ease of troubleshooting and service for those few that may require attention.

The circuit board and faceplate snap into the bezel and plug into the wiring with one connector allowing you to troubleshoot the system within seconds, by unplugging the board and plugging a new one in. No wires ever have to be disconnected from the system and there is no need for any special testers to pinpoint the problem. Should there ever be a problem with the circuit board, it can be sent in to KIB for repair while the rest of the system remains wired up. This allows the

use of the pump, fan, etc. and there isn't any holes in the wall from removal of the bezel during that time the circuit is being repaired.

We at KIB are very excited about the K-Panel series of monitors. We feel this will give you and your customers the very best in features and trouble free operation. Not discounting the ease of serviceability if ever required.

K-Panel Battery Read Out

	1988	2-91	1-92
CHARGE	14.5	13.3	12.7
(CONVERTER)			
GOOD	12.6	12.6	11.9
FAIR	12.0	12.0	11.2
LOW	6.0	6.0	6.0
ALL VALUES D.C. VOLTS + OR -5%			

M-PANEL SYSTEMS

FUNCTIONS

Allows monitoring of fresh water, gray water, black water, and battery levels. All functions are controlled from computer grade "tact" switches to easy operation. Optional functions allow monitoring of LP gas, and fourth water tank. All panels also have a lighted pump switch to control the water pump.

DECOR

The entire panel is mounted in a black ABS bezel with easy to clean matte finish lexan label for continued good appearance. The overall size is only 2.75" H x 4.5" W and it is only .75" deep when mounted on the wall.

CIRCUITRY

The electronics is using integrated circuit technology with complete voltage regulation, for the most reliable circuit design in the industry. This assures proper level displays with a wide range of input voltage from around 9VDC all the way up to 35VDC. Eliminating erroneous level display from weak batteries and power surges caused by some converters and generators. The display is lighted by solid-state L.E.D.'s to eliminate burnout problems.

POWER REQUIREMENTS

The system only draws power when a switch is on, causing no battery to drain while not in use. The monitor panel display consumes 75ma. maximum with all options and only during the time a switch is pushed on. The only other consumption is the draw of your pump, when it is in use.

INSTALLATION

The monitor panel attaches to the all with four #4 flat head screws and the faceplate with the circuitry snaps into the bezel over these screws for a very clean appearance.

The tanks have a very small pigtail attached to your probes requiring only one wire to return to the panel from each tank and one combined ground wire for all the tanks. These wires can be as low as 22 gauge,

eliminating the need for a bulky and expensive multi-wire harness to go to each tank.

SERVICEABILITY

This system is designed for trouble free operation, however, it is also designed for ease of troubleshooting and service for those few that may require attention.

The circuit board and faceplate snap into the bezel and plug into the wiring with one connector allowing you to troubleshoot the system within seconds, by unplugging the board and plugging a new one in. No wires ever have to be disconnected from the system and there is no need for any special testers to pinpoint the problem. Should there ever be a problem with the circuit board, it can be sent in to KIB for repair while the rest of the system remains wired up. This allows the use of the pump and there isn't any holes in the wall from the removal of the bezel during that time the circuit is being repaired.

We at KIB feel this will give you and your customers the very best features and trouble free operation. Not discounting the ease of serviceability if ever required.

M-Panel Battery Read Out

CHARGE	12.7	TO	12.85
GOOD	12.10	TO	12.15
FAIR	11.60	TO	11.65
LOW	6.0	TO	

ALL VALUES D.C. VOLTS + OR -5%

DIAGNOSIS GUIDE FOR THE KIB MONITOR SYSTEM

ISOLATE THE MALFUNCTION

A. Monitor Panel

1. Printed Circuit Board

- a. Damage
 1. Short Circuit
 2. Broken Component
- b. Defective
 1. Component Failure

2. Switch

- a. Damage
 1. Broken
- b. Defective
 1. Mechanical Failure

B. Wiring

1. Coach Wiring

- a. Open Wire
- b. Shorted Wire

2. Connectors

- a. Loose or Open

C. Tank

1. Inserts (Probes)

- a. Placement

2. Pigtail (K101)

- a. Damage/Defective
 1. Open Circuit
 - a. Cracked Resistor
2. See Test Procedure

TROUBLE SHOOTING FULL SYSTEM

PROBLEM: No lights on panel when switch is pushed.

- TEST:**
1. Make sure B+ wire (red) has 12 VDC connected,
 2. Make sure ground wire (white) is connected to panel.

DIAGNOSIS: 1. Correct wiring or voltage supply problem.

- A. Polarity
- B. Fuse
- C. Open Wire

2. If 12 volts DC and ground is present at panel but display is still dead replace printed circuit board.

TROUBLE SHOOTING TANKS

PROBLEM: Displays "E" on one or more tanks but not all.

- TEST:**
1. Verify that levels in tanks do not match display.
 2. Swap tank connectors on panel (i.e., if the problem is in "fresh" but grey is good, swap the fresh wire "blue" with the grey tank wire "grey". Retest tank functions to see if problem has also changed to another tank or is still in same tank.

DIAGNOSIS: 1. If step (2) still displays "E" on the same tank, replace printed circuit board.

2. If step (2) above displays "E" on different tank when the problem is an open connection in that tank wiring or pigtail. Repair or replace wiring or pigtail.
3. Open connection in either ground or signal wire will show "E" on tank display.

PROBLEM: Displays "F" on one or more tanks, others test good.

- TEST:**
1. Verify that levels in tanks do not match display.
 2. Swap tank connections on panel as for previous problem. Retest tanks to see if problem has also changed to another tank or is still in the same tank.

DIAGNOSIS: 1. If step (2) above still displays "F" on the same tank, replace printed circuit board.

2. If step (2) above displays "F" on different tank, when the problem maybe a short in the wiring. A signal wire shorted to ground will display "F" on the panel. Repair or replace wiring.

PROBLEM: False readings (i.e., 1/3 or 2/3 indication in an empty tank).

- TEST:**
1. Verify tank is empty.
 2. Open pigtail ground wire (white).
 3. Check probe placement in tank. This very critical in single wire systems. **See placement diagrams.**

DIAGNOSIS: 1. If display changes to "E" after step (2) above and probes are not placed correctly abandon and install probes in the proper position.

2. Retest tank.

TROUBLE SHOOTING LPG

PROBLEM: Display indicates "E" all the time.

- TEST:**
1. Verify tank is not empty.
 2. Verify wire from 90 OHM sending unit to orange wire on back of panel is not shorted to ground.
 3. Check sending unit for damage or sticking.

DIAGNOSIS: 1. Add gas to tank and retest.

Monitor Panel

2. Run continuity test on wire, end to end and to system ground (short test).
3. Replace sending unit if found defective.

PROBLEM: Display indicates "F" all the time

TEST: 1. Disconnect orange wire. If display is "E", problem is in wiring or sending unit.

DIAGNOSIS: 1. If problem is in wiring or sending unit as indicated above, check for open connection or bad sending unit.
2. If display still indicates "F", replace printed circuit board.

K101 PIGTAIL TEST PROCEDURE

The K101 pigtail can be tested with an OHM meter as follows:

Red to Orange - 0 OHMS

Red to Green - 68K OHMS +/-5%

Red to Yellow - 188K OHMS +/-5%

NOTE: Do not short fresh tank probes with jumper wires. Water test or use a 43K OHM resistor for this testing.

Replace only defective components i.e., PCB/Switch/Pigtail

KIB Technical: Phone: (219) 262-0518 and Fax:(219) 262-5172

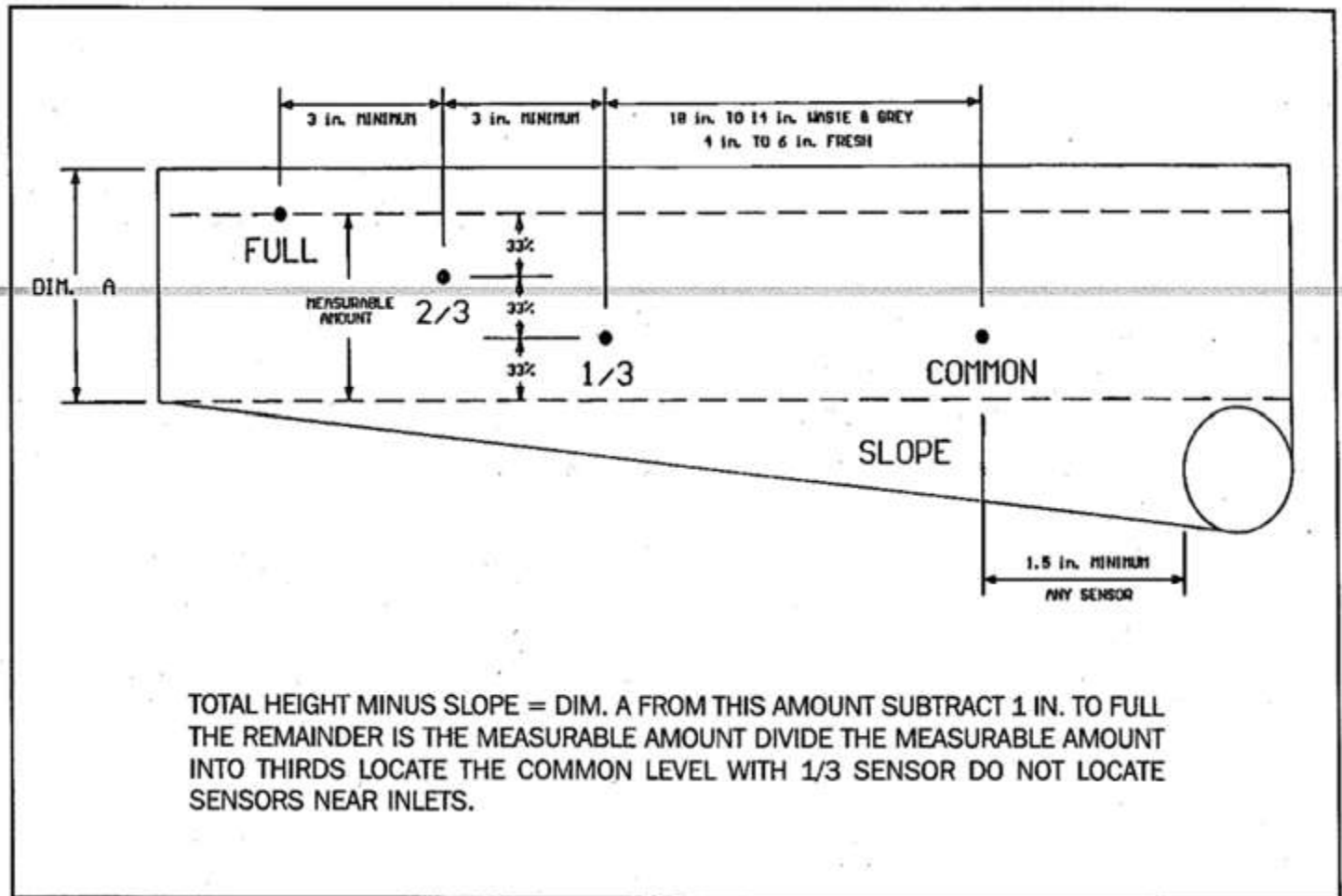

K-PANEL WIRING DIAGRAM

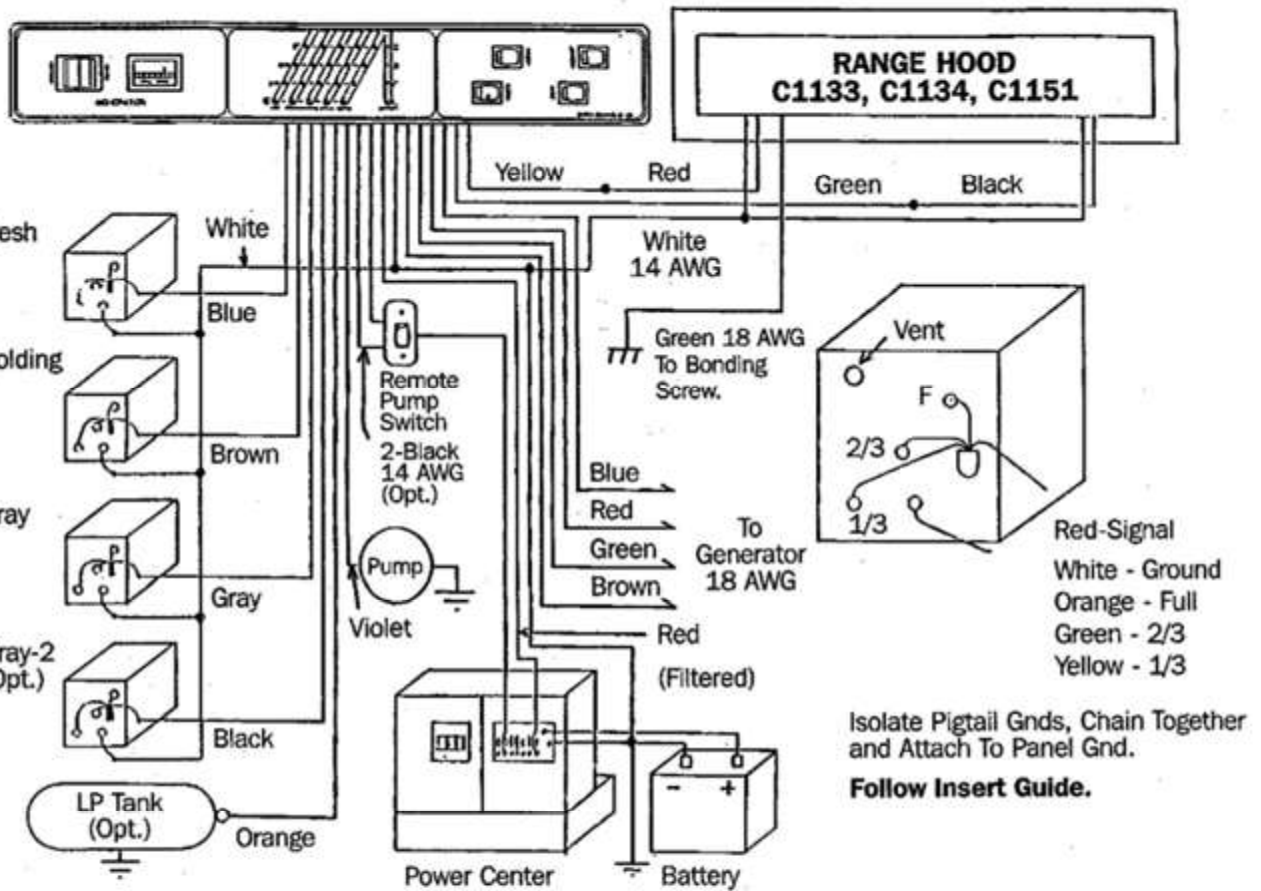
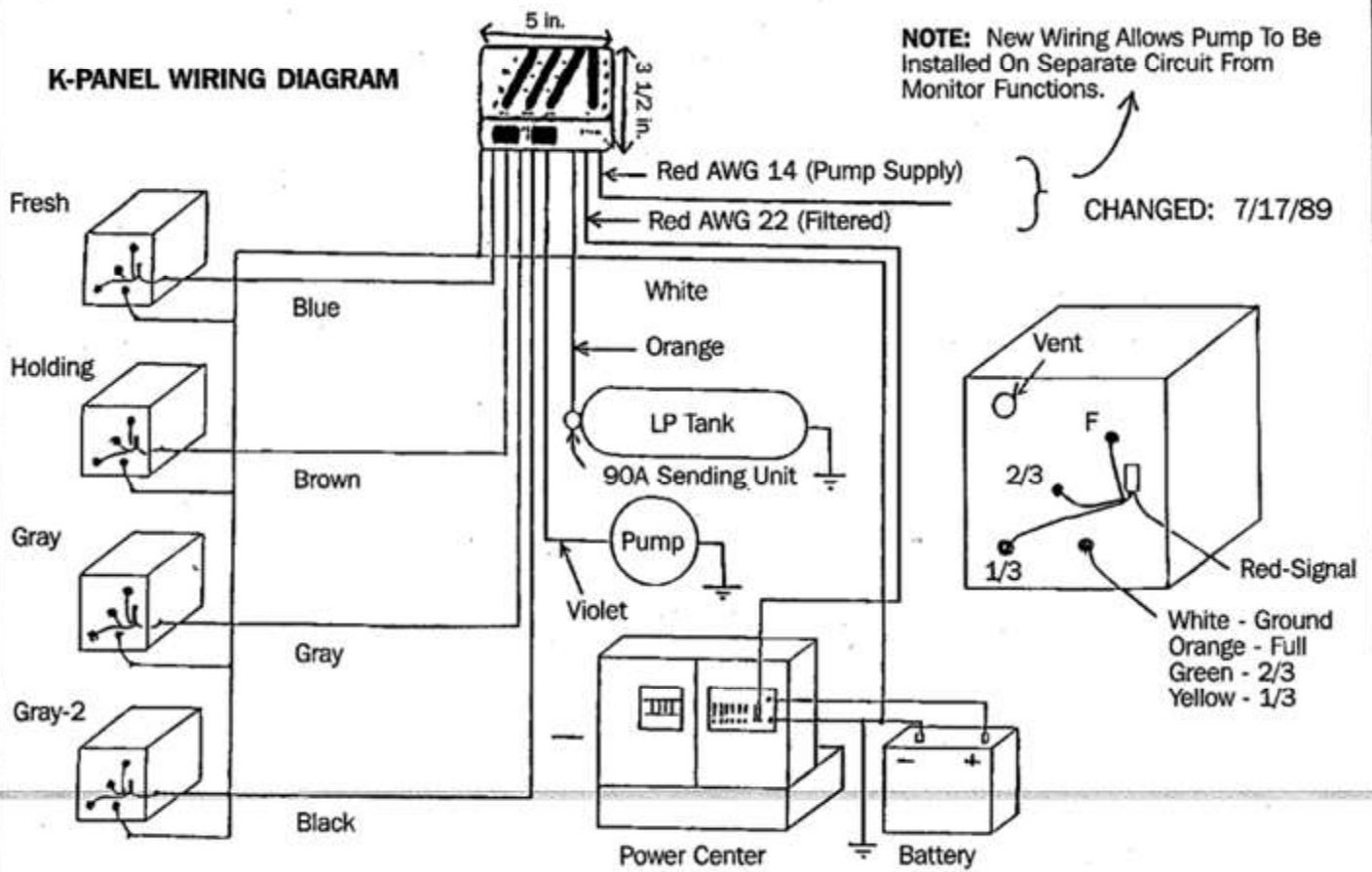

MP5 INSTALLATION INSTRUCTIONS

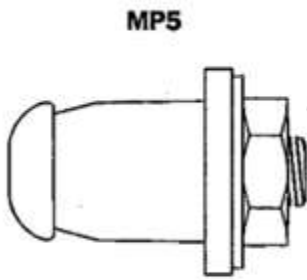

MP5

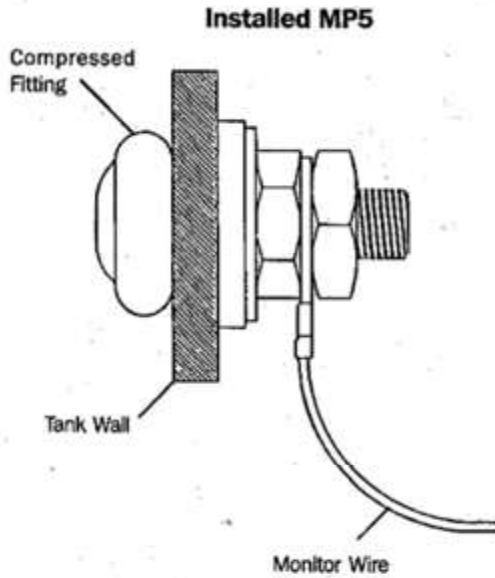

Installed MP5

1. Mark tank according to placement guide. It is best to make templates to standardize and speed this process.
2. Drill Holes
 - a. Use 3/8 in. Bit.
 - b. Drill at low speed.
 1. High speed drilling can cause burns.
 2. Remove any burrs.
 - c. Drill at 90 degree angle to tank, angled holes can cause leaks.
3. Insert MP5 in hole.
4. Remove top nut.
5. Tighten bottom nut until snug.
 - a. Do not over-tighten.
 - b. It is best to use a nut driver or a torque adjustable screw gun.
 - c. Set torque at 100 in/oz.
6. Attach wire with nut removed earlier.
7. Seal exposed connections with a red battery spray or silicone sealer.
 - a. This is not necessary for tanks covered by underbelly.

WIRING LEGEND	
RED 20 AWG - FILTERED POSITIVE	
RED 14 AWG - POSITIVE ACC PUMP	
VEHICLE 14 AWG - PUMP	
WHITE - HOLDING 1 TANK	
YELLOW - HOLDING 2 TANK	
BLUE - FRESH TANK	
GREY - GREY 1 TANK	
BLACK - GREY 2 TANK	

REPLACEMENT PARTS	
PRINTED CIRCUIT BOARD - 4 SUPPLIES	
PUMP SWITCH - 8 BACKLASH	
TEST SWITCH - 8 SUPPLIES	
SWITCH BUTTON - 8 SUPPLIES	
RESISTOR PISTON - 8 K102	

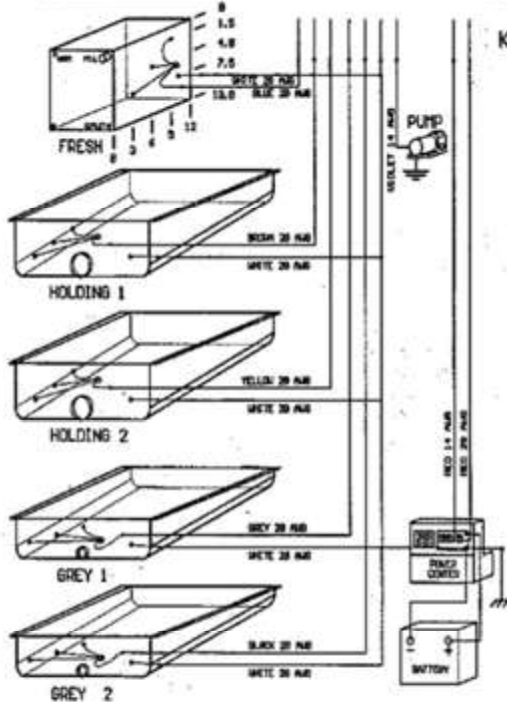
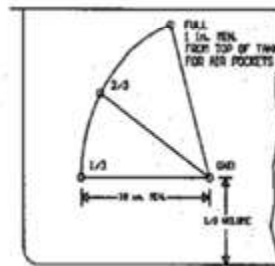
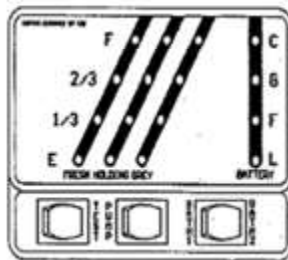

K21X2

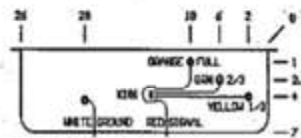

PLACE 1/3 AND GROUND INSIDE AT 1/3 HOLES.
 PLACE GROUND INSIDE NO LESS THAN 1/8 IN FROM OTHER
 INSERTS IN HOLES AND SEET THEM. USE ALL AVAILABLE
 SPACE.
 ALL HOLDING & LPS TANK GROUNDS MUST BE ATTACHED TO
 MONITOR GROUND.

MP5 PROBE INSTALLATION

MARK TANK PER PLACEMENT GUIDE.
 DRILL HOLES USING 3/8 IN. BIT, DRILL AT LOW SPEED.
 INSERT MP5 INTO HOLE.
 REMOVE TOP 3/4 IN NUT
 TIGHTEN BOTTOM NUT UNTIL SNUG, DO NOT OVER TIGHTEN
 USE NUT DRIVER, DO NOT USE SCREW GUN
 ATTACH WIRE WITH NUT REMOVED EARLIER
 SEAL EXPOSED CONNECTIONS WITH RED BATTERY SPRAY OR
 SILICON SEALER

KIB Enterprises Corp.	
TYPE: K21X2 WIRING DIAGRAM	REV: 8
DRAWN BY: S.F. Paulson	DATE: 6-19-88

M28 WIRING LEGEND	
RED	- FILTERED POSITIVE
WHITE	- GROUND
GREY	- GREY TANK
BROWN	- HOLDING TANK
BLUE	- FRESH TANK
RED 14 AWG	- PUMP SUPPLY - + 12VDC
VIOLET 14 AWG	- WATER PUMP

REPLACEMENT PARTS	
PRINTED CIRCUIT BOARD	- # SUBCP028
PUMP SWITCH	- # BK0KLE01
RESISTOR PISTON	- # K308

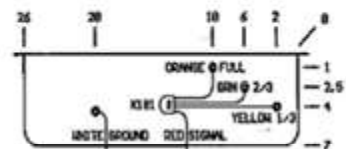
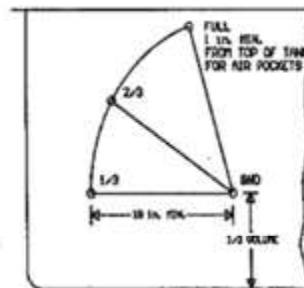
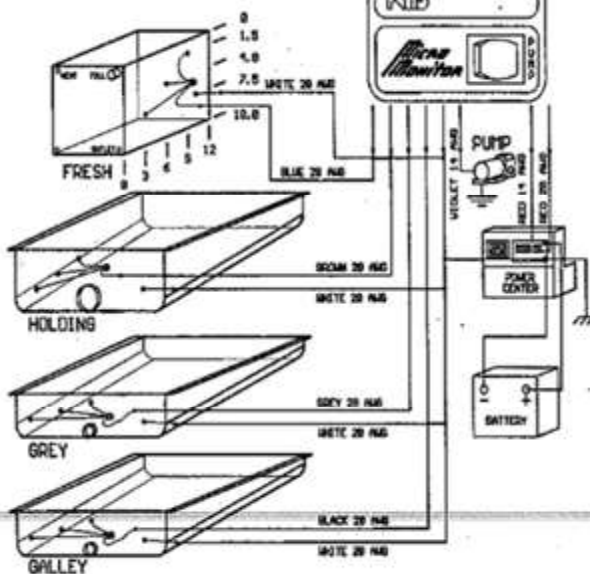

PLACE 1/3 IN. GROUND INSERT AT 1/3 VOLUME.
 PLACE GROUND INSERT NO LESS THAN 18 IN. FROM OTHER INSERTS IN HOLDING AND GREY TANKS. USE ALL AVAILABLE SPACE.
 ALL HOLDING & LPG TANK GROUNDS MUST BE ATTACHED TO MONITOR GROUND.

MPI PROBE INSTALLATION

MARK TANK PER PLACEMENT GUIDE.
 DRILL HOLES USING 3/8 IN. BIT. DRILL AT LOW SPEED.
 INSERT MPI INTO HOLE.
 REMOVE TOP 3/8 IN. NUT
 TIGHTEN BOTTOM NUT UNTIL SNUG, DO NOT OVER TIGHTEN
 * USE NUT DRIVER, DO NOT USE SCREW DRIVER
 ATTACH WIRE WITH NUT REMOVED EARLIER
 SEAL EXPOSED CONNECTIONS WITH RED BATTERY SPRAY OR SILICON SEALER

M28 WIRING LEGEND	
RED	- FILTERED POSITIVE
WHITE	- GROUND
GREY	- GREY TANK
BROWN	- HOLDING TANK
BLUE	- FRESH TANK
RED 14 AWG	- PUMP SUPPLY - + 12VDC
VIOLET 14 AWG	- WATER PUMP

REPLACEMENT PARTS	
PRINTED CIRCUIT BOARD	- # SUBCP028
PUMP SWITCH	- # BK0KLE01
RESISTOR PISTON	- # K308

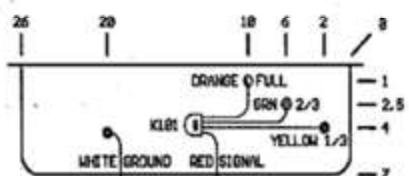
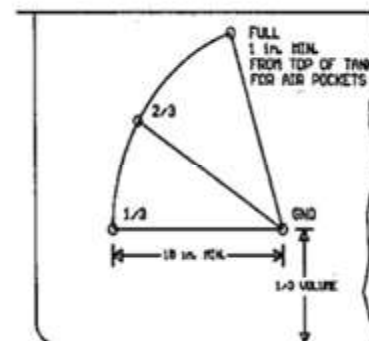
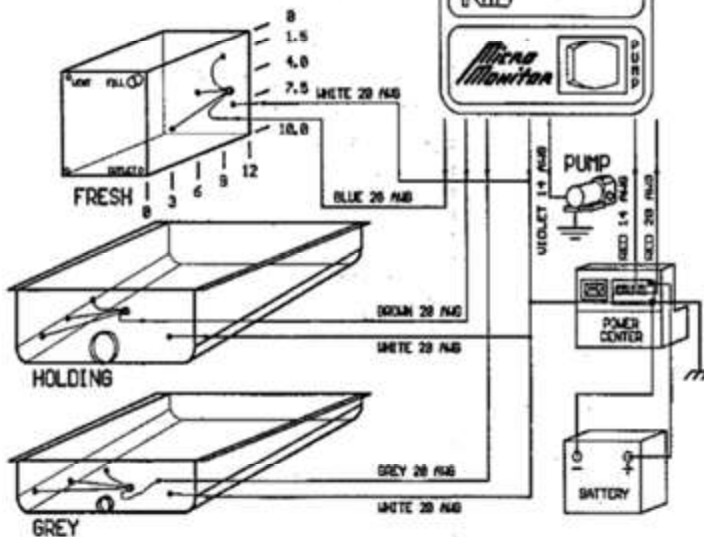

PLACE 1/3 IN. GROUND INSERT AT 1/3 VOLUME.
 PLACE GROUND INSERT NO LESS THAN 18 IN. FROM OTHER INSERTS IN HOLDING AND GREY TANKS. USE ALL AVAILABLE SPACE.
 ALL HOLDING & LPG TANK GROUNDS MUST BE ATTACHED TO MONITOR GROUND.

MPI PROBE INSTALLATION

MARK TANK PER PLACEMENT GUIDE.
 DRILL HOLES USING 3/8 IN. BIT. DRILL AT LOW SPEED.
 INSERT MPI INTO HOLE.
 REMOVE TOP 3/8 IN. NUT
 TIGHTEN BOTTOM NUT UNTIL SNUG, DO NOT OVER TIGHTEN
 * USE NUT DRIVER, DO NOT USE SCREW DRIVER
 ATTACH WIRE WITH NUT REMOVED EARLIER
 SEAL EXPOSED CONNECTIONS WITH RED BATTERY SPRAY OR SILICON SEALER