

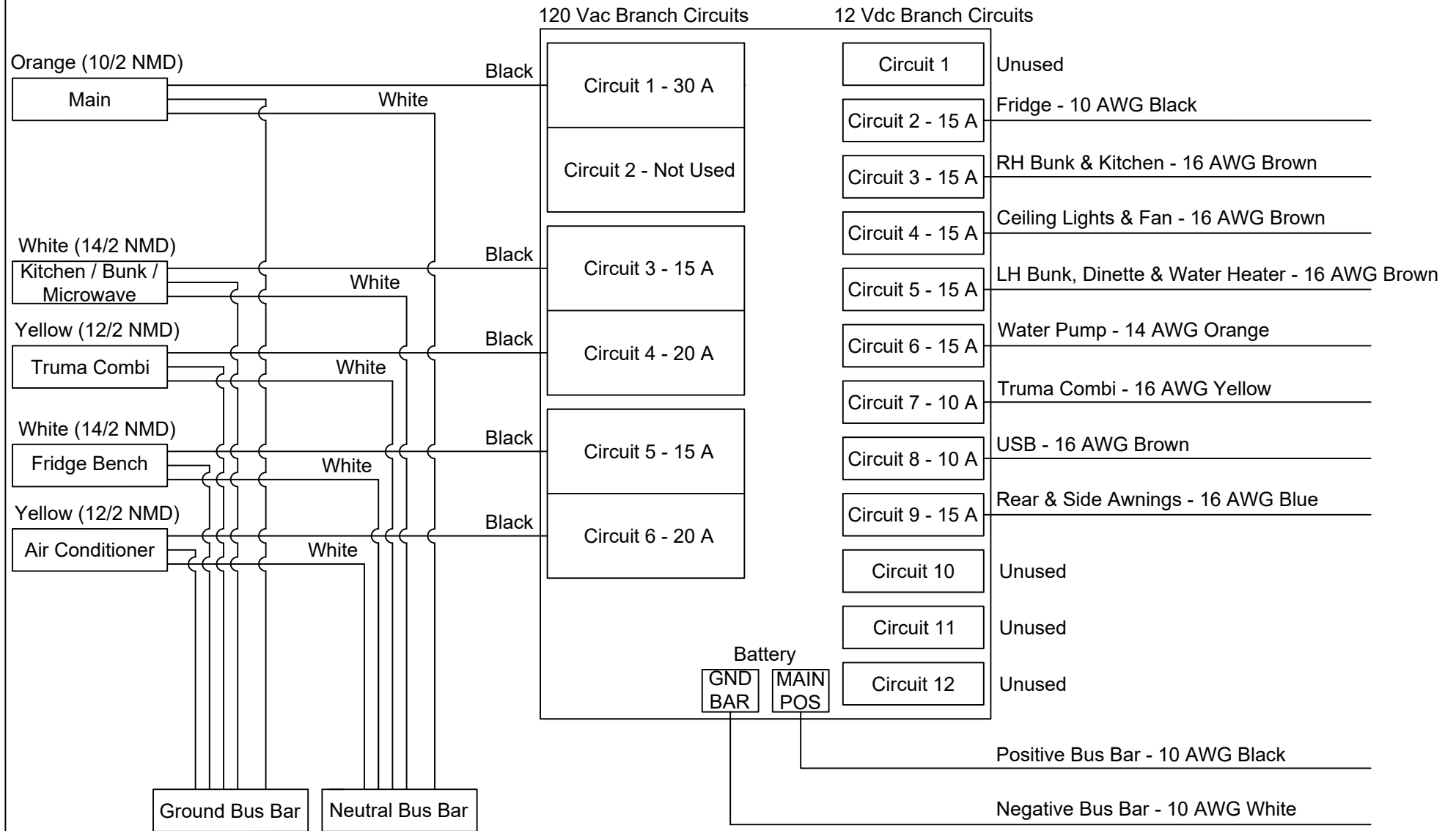

Prepared	SD
Checked	SD
Approved	MH DD Mmm YY
Material	N/A



This drawing is the property of Northern Lite Mfg. Limited Partnership and is intended solely for the use of the party to whom it is issued. It may not be reproduced, copied, distributed, or disclosed to third parties without prior written consent. The information contained herein is confidential and provided "as is" without warranties of any kind, express or implied. All dimensions must be verified on site. Northern Lite Mfg. Limited Partnership assumes no responsibility for errors, omissions, or changes made to the drawing without authorization.

Title 600 Ah Option Block Diagram		Sheet 1/1
Drawing No. S-S-ELEC-0002-02		Rev 02



Prepared	SD		<p>This drawing is the property of Northern Lite Mfg. Limited Partnership and is intended solely for the use of the party to whom it is issued. It may not be reproduced, copied, distributed, or disclosed to third parties without prior written consent. The information contained herein is confidential and provided "as is" with no warranties of any kind, express or implied. All dimensions must be verified on site. Northern Lite Mfg. Limited Partnership assumes no responsibility for errors, omissions, or changes made to the drawing without authorization.</p>
Checked	SD 02 Jul 25		
Approved	MH 02 Jul 25		
		Title	Distribution Panel Wiring Diagram
			Sheet 1/